

Assembly instructions

High Round Bench & High Round Planter

Table of contents

Product info U11-58ERH High Round Bench	s. 2
Product info U11-58ERP High Round Planter	s. 3
Information planter insert	s. 4
Assembly High Round Bench / Planter	s. 5
Ground mounting	s. 6
Maintenance and disassembly	s. 7

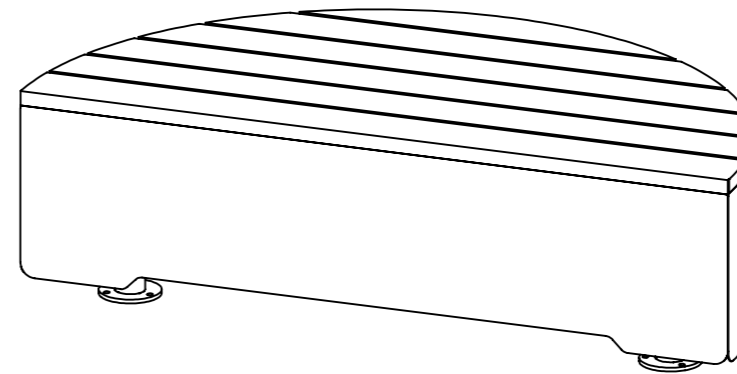

U11-58ERH
High Round Bench

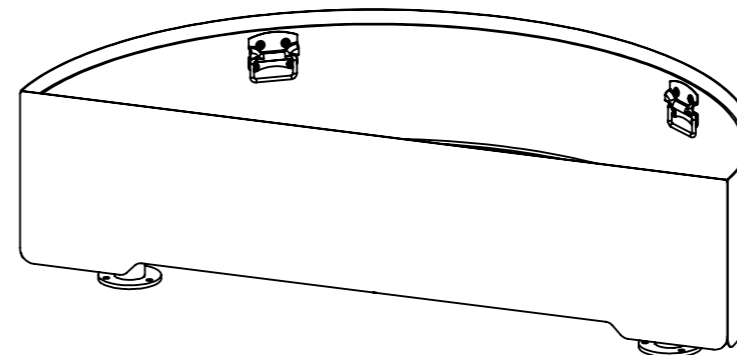

U11-58ERP
High Round Planter

High Round Bench

Product information

Drawing by Odin Sollie
2023-03-21

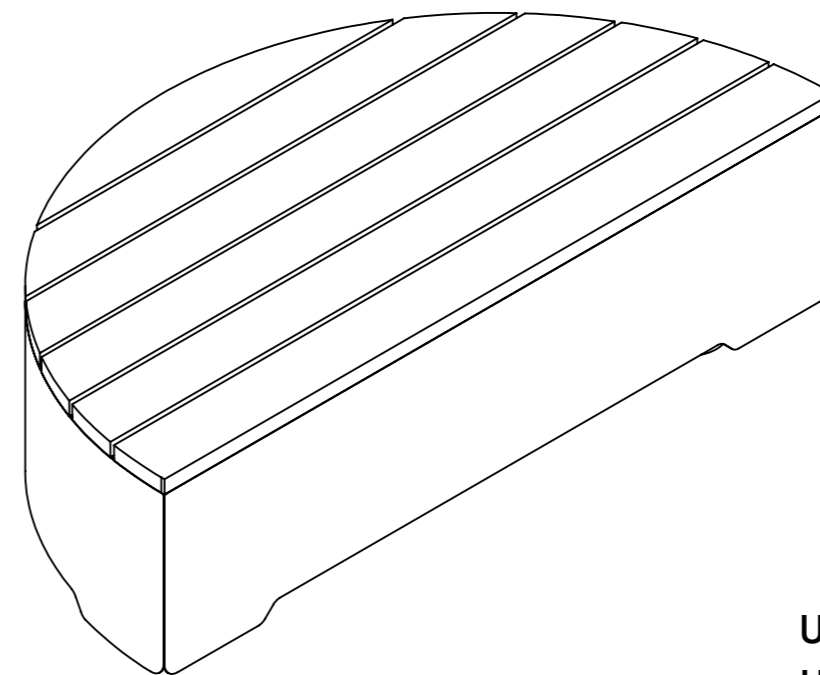
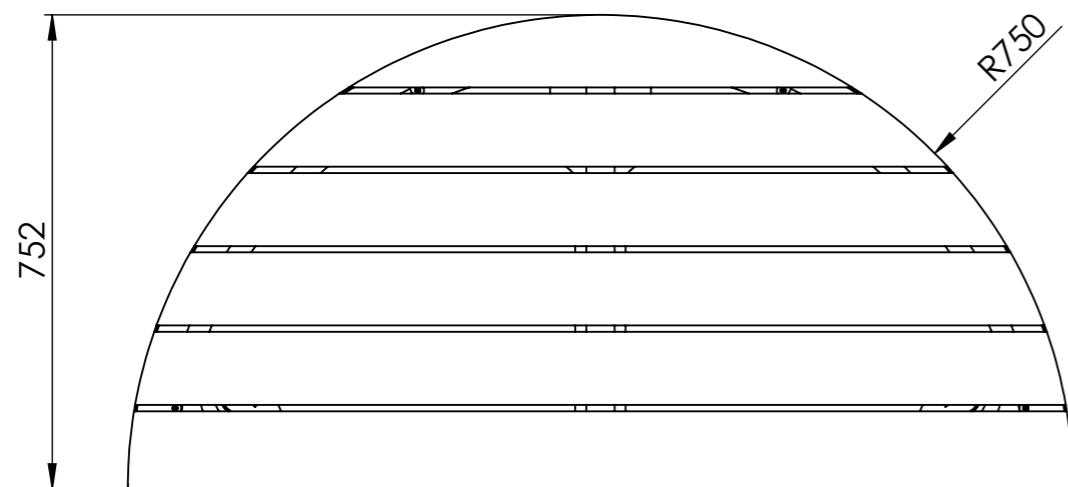
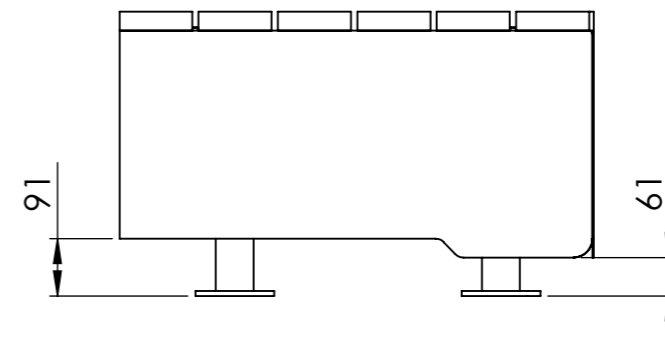
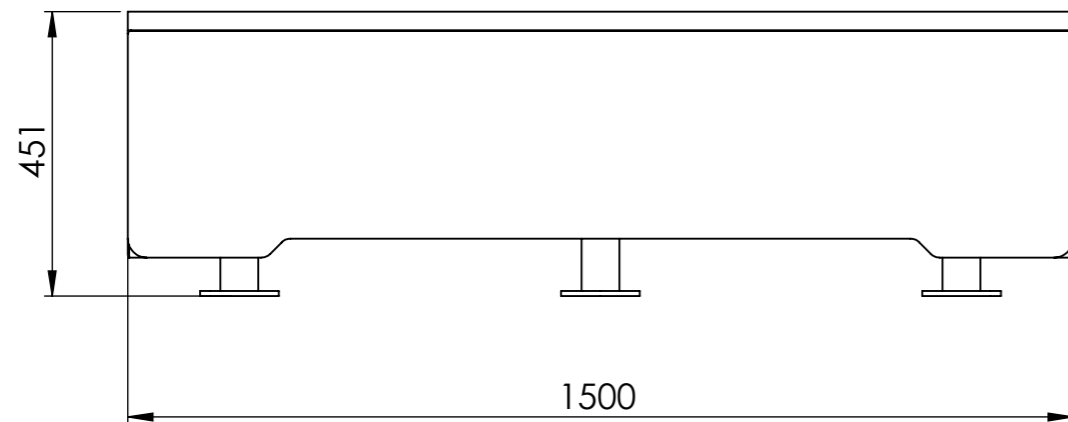

U11-58ERH
High Round Bench
Weight 69 kg

Delivered fully assembled

High Round Planter

Product information

Drawing by Odin Sollie
2023-03-21

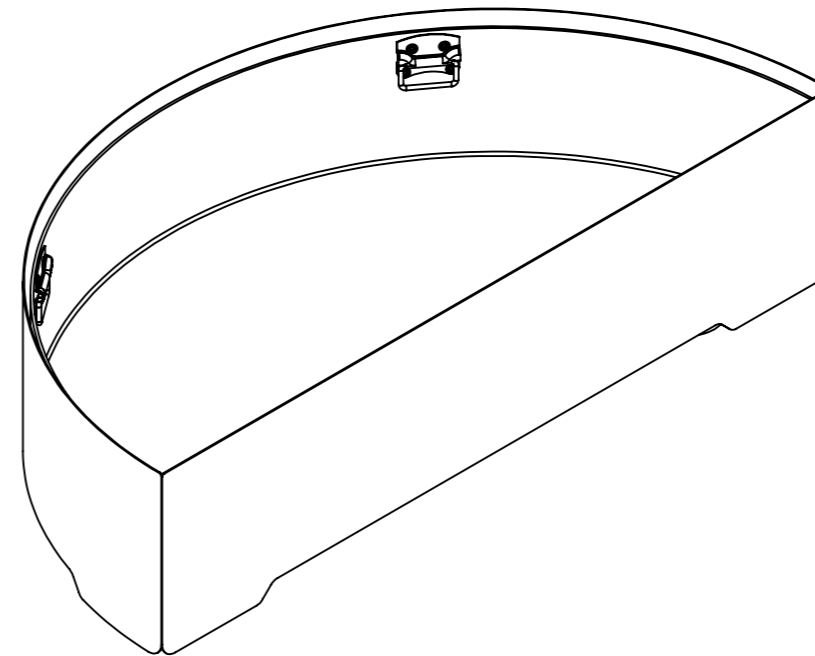
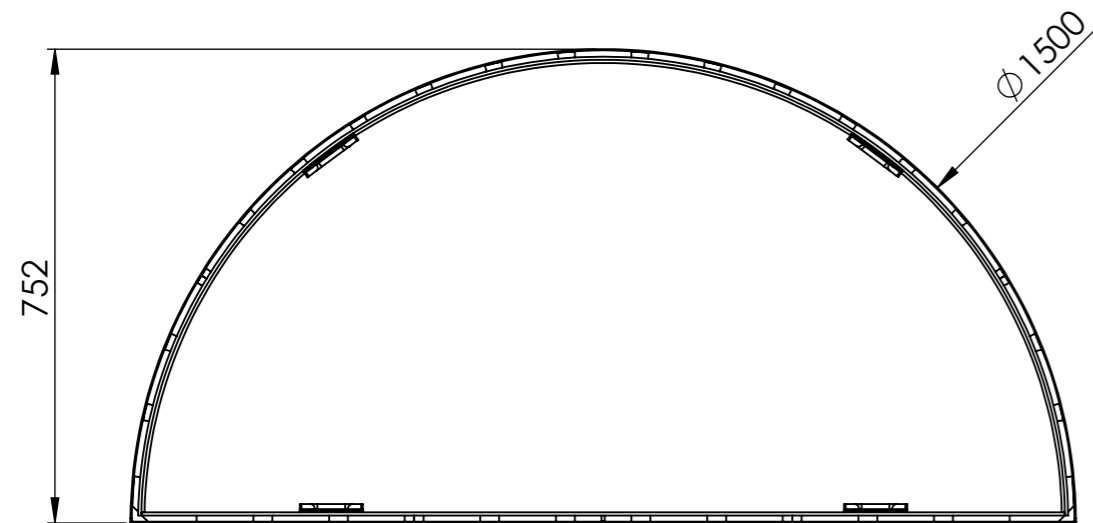
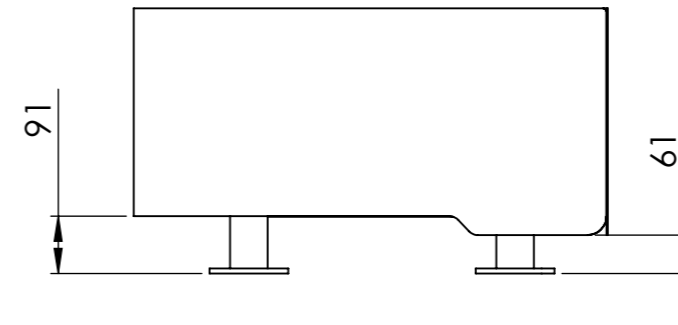
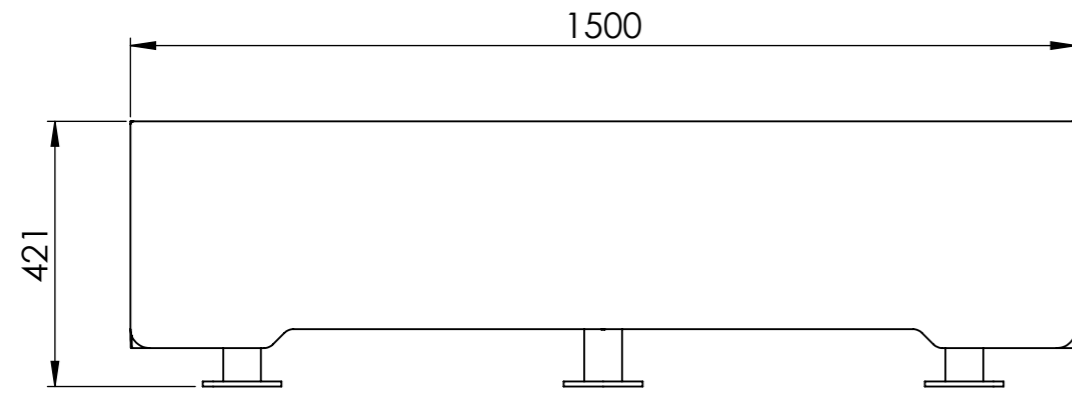

U11-58ERP
High Round Planter
Weight 45,5 kg
Delivered fully assembled
Including planter insert

Planting insert Produktinformation

Ritad av Odin Sollie
Ritad datum 2023-03-21

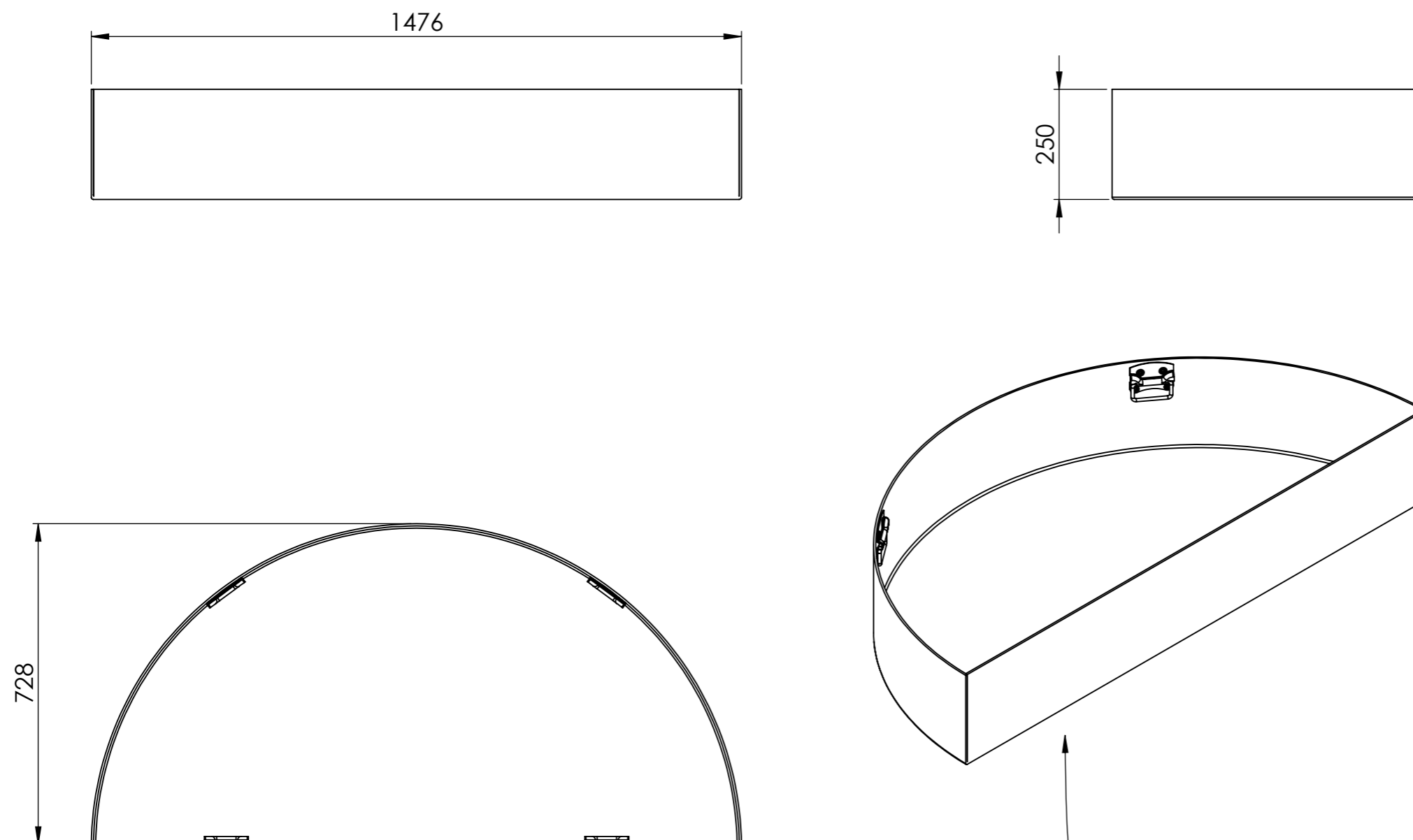

Planter insert
Weight 8,5 kg, Volume 200 litres
Delivered assembled

The planting insert material is PEHD and has 4 handles for lifting. Lift only by hand as the use of a machine enables lifting of an over filled planter insert which may fail.

If the planter is mainly stationed outdoors the planter insert must have drainage. Depending on the types of plants that are intended, holes can be drilled either in the bottom or the lower sides of the insert for the drainage level needed.

High Round Bench och Planter Assembly

Drawing by Odin Sollie
2023-03-21

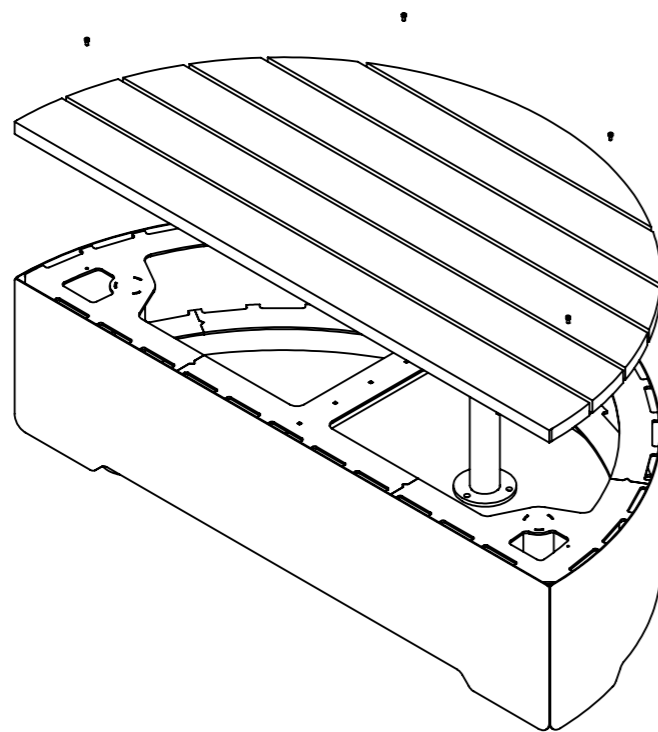
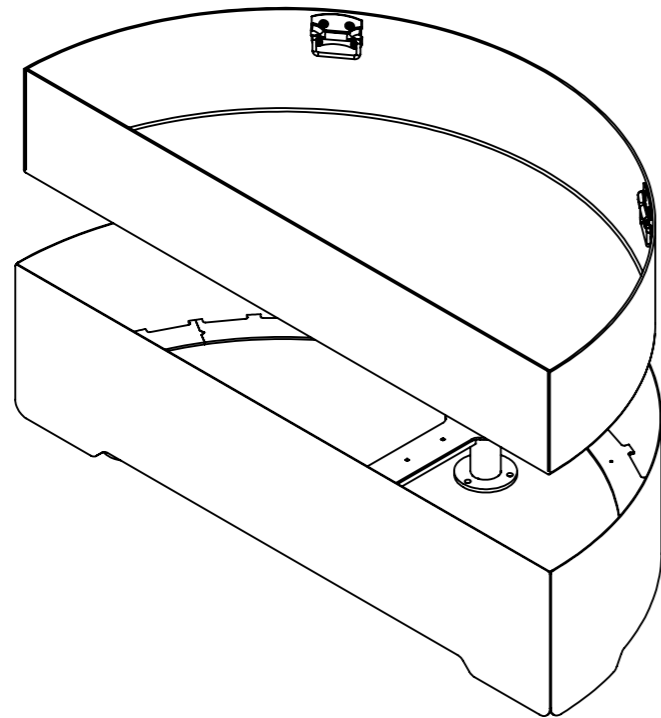

Assembly High Round Bench and Planter

The bench and planter are both delivered fully assembled and can be placed freely without any further actions taken. If they are meant to be fixed to the ground, the feet need to be exposed before installation. For the bench please follow the instructions below. For the planter simply lift out the planter insert and follow the same instructions from point 3.

- 1) Unscrew the four M5 hex screws which are found between the planks of the seat.
- 2) Remove the seat and place to the side to access the feet.
- 3) Place the furniture at the intended spot and mark the placement of the fixing holes.
- 4) Move the furniture to the side, drill and prepare the ground for installation.
- 5) Move the furniture back and fasten it to the ground followed by reattachment of the seat.

In the case of installation on a wooden surface the screw holes can be carefully drilled directly through the holes of the feet without the need to move the furniture to the side.

High Round Bench och Planter

Ground mounting

Ritad av Odin Sollie
Ritad datum 2023-03-21

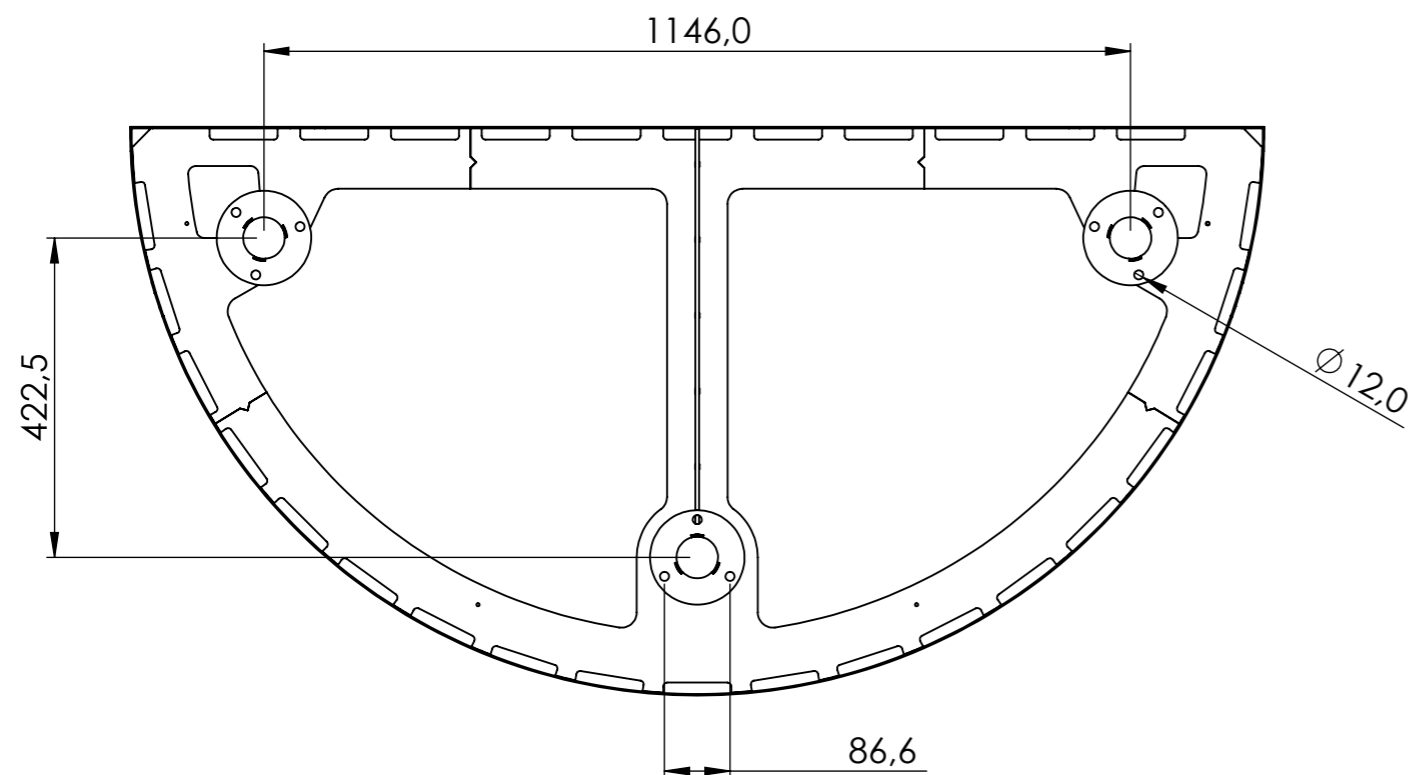

The holes in the footplates have a diameter of $\varnothing 12\text{mm}$ and are intended for attachment with an M10 screw. The feet of the bench and the planter have the same positions and centre to centre measurements.

Installation on wooden decks

- Pre-drill and install with wood screws.
- Do not drill through the holes of the footplates as the paint may be damaged.

Installation on paving stones or paving slabs

- Remove paving stones/slabs where foundations are to be cast
- Undercast the slabs with concrete, follow the general advice below
- Restore the surface with paving stones or tiles
- If the tiles are placed loose on the concrete, make sure that there is no setting sand between the the slabs and the concrete
- Drill slab and concrete for expander or chemical anchor.

Installation on a concrete surface

- Drill the concrete for expanders or chemical anchors

Installation on gravel or grass

- Follow the steps under general advice below
- In the holes, place or pour a foundation so that the top is at ground level
- The top of the foundation can be finished with a radius for better water drainage
- Drill the foundations for expanders or chemical anchors

General advice for installing concrete foundations

- To frost-free depth, dig one hole per leg with the diameter of the intended foundation
- Prepare bottom of hole with draining/non-frost heaving material
- Fill with sufficient material that the depth of the hole corresponds to the intended height of the foundation.
- Place or cast the foundation in the hole, preferably using a cardboard tube.
- Restore the ground surface.

Mounting with an expander provides a removable attachment.

Installation with chemical anchors provides a permanent attachment.

High Round Bench och Planter

Underhåll och demontering

Ritad av Odin Sollie
Ritad datum 2023-03-21

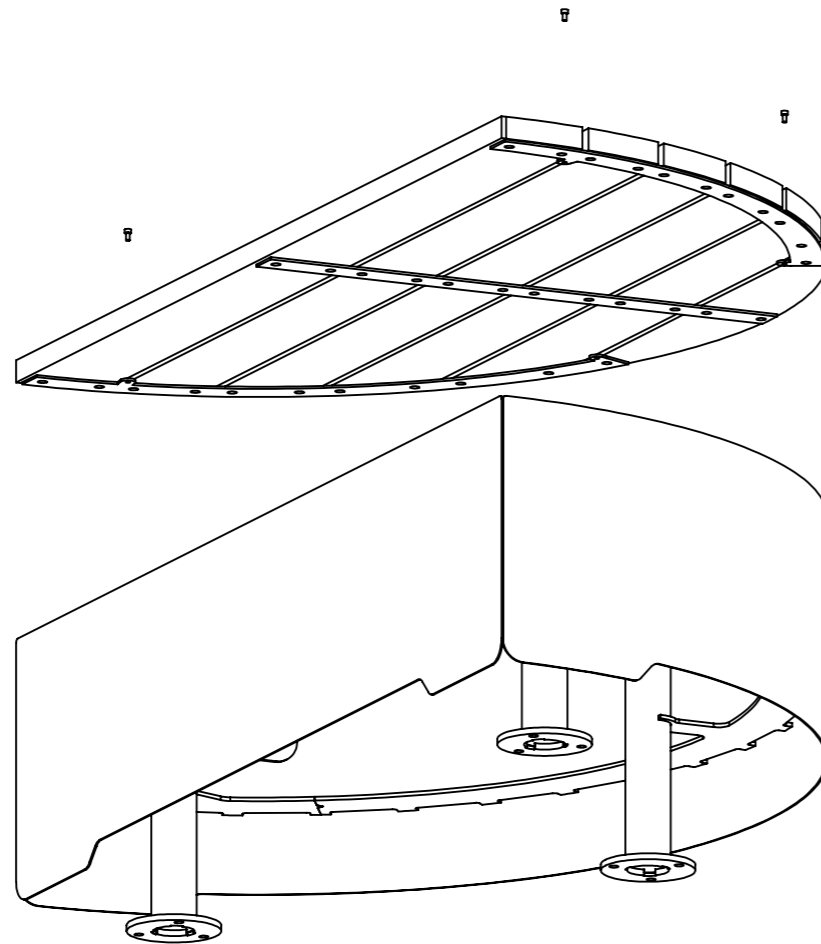

Maintenance

Damage to powder coated surfaces can be repaired with alkyd paint in corresponding colour. Please contact Nola for any questions about paint.

The proper maintenance and care of wooden surfaces depends on the wood type. Information on how to properly maintain any specific wood type can be found in the document "advice about maintenance". This can be downloaded from our website www.nola.se

Disassembly

To repair or replace any of the planks, the seat needs to be removed to reach the wood screws. Please follow the instructions on page 4 on how to remove the seat.

For comprehensive maintenance at the manufacturer or for recycling at an appropriate facility the furniture is best transported fully assembled.