

Albert

Bænk · Plint · Bord
Bench · Plinth · Table



Design:
Nation & KSA Design
+ Møller & Grønborg

SPECIFIKATIONER . SPECIFICATIONS



Stel til bænk, plint og bord er fremstillet i 15 x 100 mm stål, der efterfølgende er varmgalvaniseret iflg. DS/EN ISO 1461. Kan eventuelt pulverlakeres i standard RAL farver efter ønske.

Sæde, ryg og bordplade af oliebehandlede egeplanker 1800 x 192 x 45 mm.

Kan leveres med armlæn. Armlæn er fremstillet i stål 10 x 80 mm.

The frame for bench, plinth and table is made of 15 x 100 mm steel which is hot dip galvanized. Available powder coated in standard RAL colours on request.

Seat, back and table top are made of oil treated oak 1800 x 192 x 45 mm.

Available with armrest. Armrest is made of steel 10 x 80 mm.



PRODUKTER . PRODUCTS

Albert serien omfatter:

- | | |
|---------------------|--|
| Bænk Albert 1800 N | Til nedstøbning i beton eller montering på præfabrikeret fundament |
| Plint Albert 1800 N | Til nedstøbning i beton eller montering på præfabrikeret fundament |
| Bord Albert 1800 N | Til nedstøbning i beton eller montering på præfabrikeret fundament |

ALBERT available as:

- | | |
|----------------------|--|
| Bench Albert 1800 N | Embedding in concrete or mounting to precast concrete base |
| Plinth Albert 1800 N | Embedding in concrete or mounting to precast concrete base |
| Table Albert 1800 N | Embedding in concrete or mounting to precast concrete base |

Albert

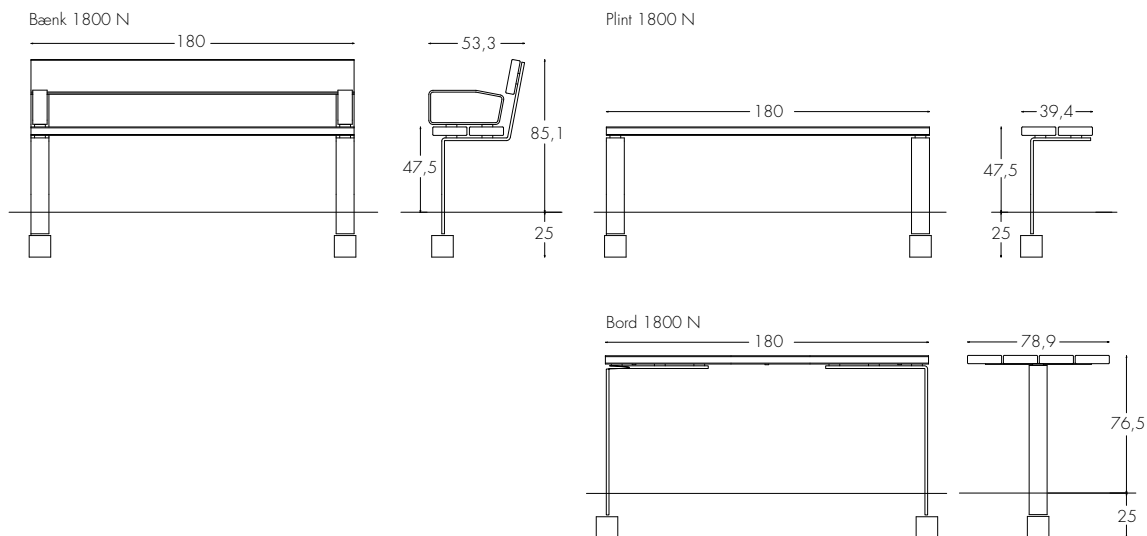

Alle mål er angivet i mm.
Ret til ændringer forbeholdes.

All dimensions in mm.
Subject to changes.

02.2016